

MODEL BB12

Brominator tablet holder manufactured from specially formulated GRP. tank with removable screw cover for filling.

Max pressure 100 psi.

Range of flow indicator
BB12 40 - 400 litres / hour

Approximate capacity of tablets 12 Kg

Do not fit a valve to the outlet as the outlet must go to an open end. If not a pressure relief/safety valve must be fitted as this is a pressure vessel.

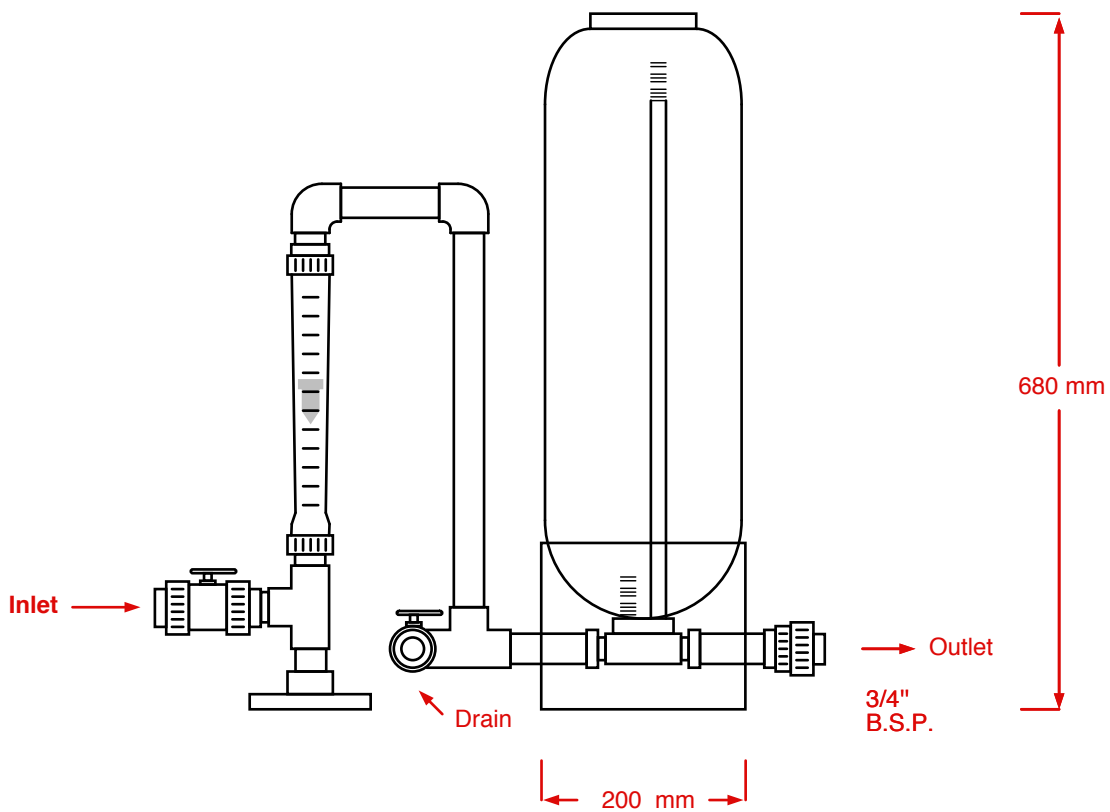

AWE. Ltd.
Antom Court Tollgate Drive Stafford
Tel. 01785 - 254597 Fax. 01785 - 257724
www. awe-ltd.co.uk email sales@awe-ltd.co.uk
Client Sales
Date 31 - 1 - 19 Drn. by K.Young
Title BB12-F